

CRYSTAL UNIT

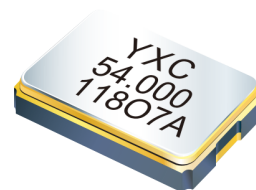

AEC-Q200

YSX530SC



Applications

- GPS Automotive electronics

Features

- Dimensions: 5.00 x 3.20 x 1.10 mm.
- Standard Frequency: 7.6 to 54MHz
- 2 pads SMD metal sealed crystal units.
- High resolution frequency tolerance is obtained.

Specifications

Standard Frequency	7.6 to 54 MHz
Vibration Mode	AT Fundamental
Load Capacitance	18pF, 20pF, or specify
Frequency Tolerance (at 25 °C)	±10ppm, ±30ppm, or specify
Frequency Versus Temperature Characteristics	±50ppm, or specify
Operating Temperature	-40~+125°C, or specify
Storage Temperature	-55~+125°C or specify
Shunt Capacitance	5 pF Max.
Level of Drive	1~300µWMax. (100uW typical)
Aging (at 25 °C)	±2ppm/year Max.

Equivalent Series Resistance(ESR)

Fundamental			
7.6 ~ 11.9MHz	100 Ω Max.	14 ~ 19.9 MHz	50 Ω Max.
12 ~ 13.9 MHz	60 Ω Max.	20 ~ 54 MHz	40 Ω Max.

Dimensions and Patterns [unit:mm]

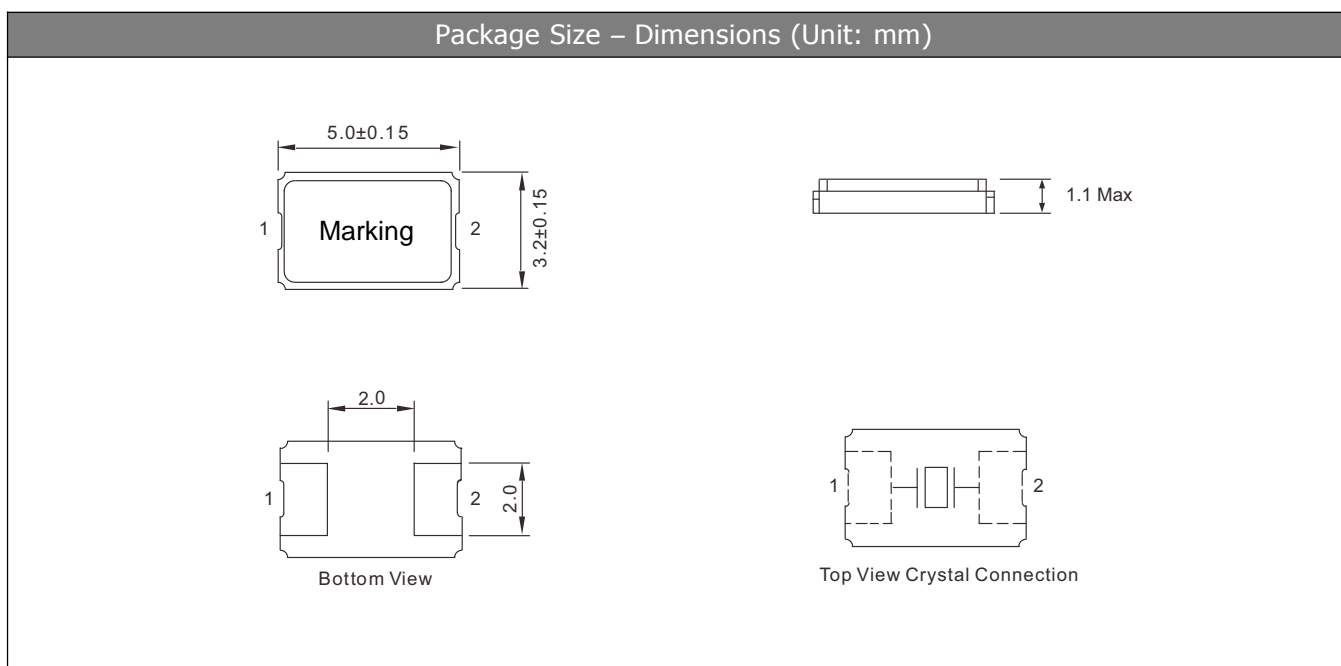

CRYSTAL UNIT

AEC-Q200

YSX530SC



Reflow Soldering Profile

Pre Heating Temperature

Tp1 ~ Tp2 = + 170 °C

Heating Temperature

TMLt = + 220 °C

Peek Temperature

TMax. = + 260 °C

Point of measuring

In case of Solder ability

Terminal.

In case of Resistance to soldering heat Surface.

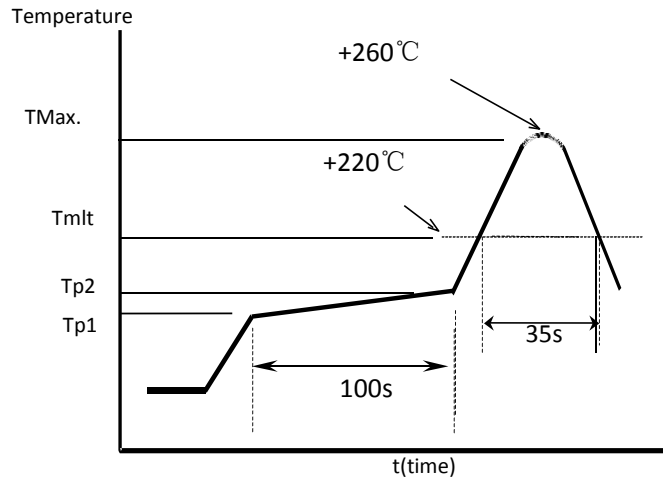

Taping Specification(Unit: mm)

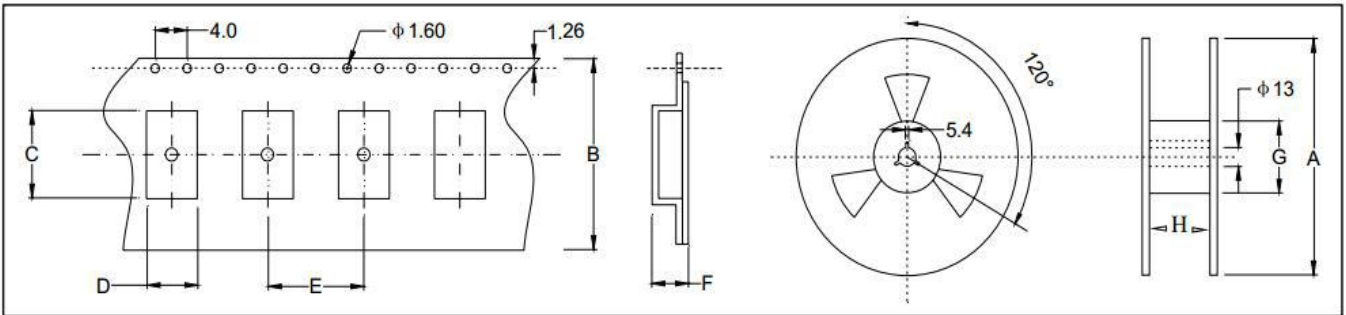

Size	A	B	C	D	E	F	G	H
SMD-5032	180±2.0	12.0±0.3	5.40±0.1	3.60±0.1	8.00±0.3	1.65±0.1	61.0±1.0	12.0±1.0
1000 pcs per reel								