

CRYSTAL UNIT



AEC-Q200

YSX321SC

Applications

- GPS Automotive electronics

Features

- Dimensions: 3.20 x 2.50 x 0.70 mm.
- Standard Frequency: 8 to 66MHz
- Low impedance performance.
- AEC-Q200 qualified.

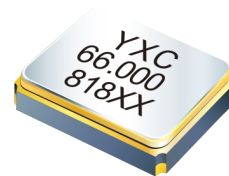

Specifications

Standard Frequency	8 to 66 MHz
Vibration Mode	AT Fundamental
Load Capacitance	8pF, 12pF, or specify
Frequency Tolerance (at 25 °C)	±10ppm, ±30ppm, or specify
Frequency Versus Temperature Characteristics	±50ppm, or specify
Operating Temperature	-40~+125 °C, or specify
Storage Temperature	-55~+125 °C or specify
Shunt Capacitance	3 pF Max.
Level of Drive	1~200µWMax. (100uW typical)
Aging (at 25 °C)	±2ppm/year Max.

Equivalent Series Resistance(ESR)

Fundamental			
8 ~ 9.9MHz	800 Ω Max.	13 ~ 15.9MHz	80 Ω Max.
10 ~ 10.9 MHz	250 Ω Max.	16 ~ 20.9 MHz	70 Ω Max.
11 ~ 11.9 MHz	150 Ω Max.	21 ~ 29.9 MHz	60 Ω Max.
12 ~ 12.9 MHz	100 Ω Max	30 ~ 66.0 MHz	50 Ω Max

Dimensions and Patterns [unit:mm]

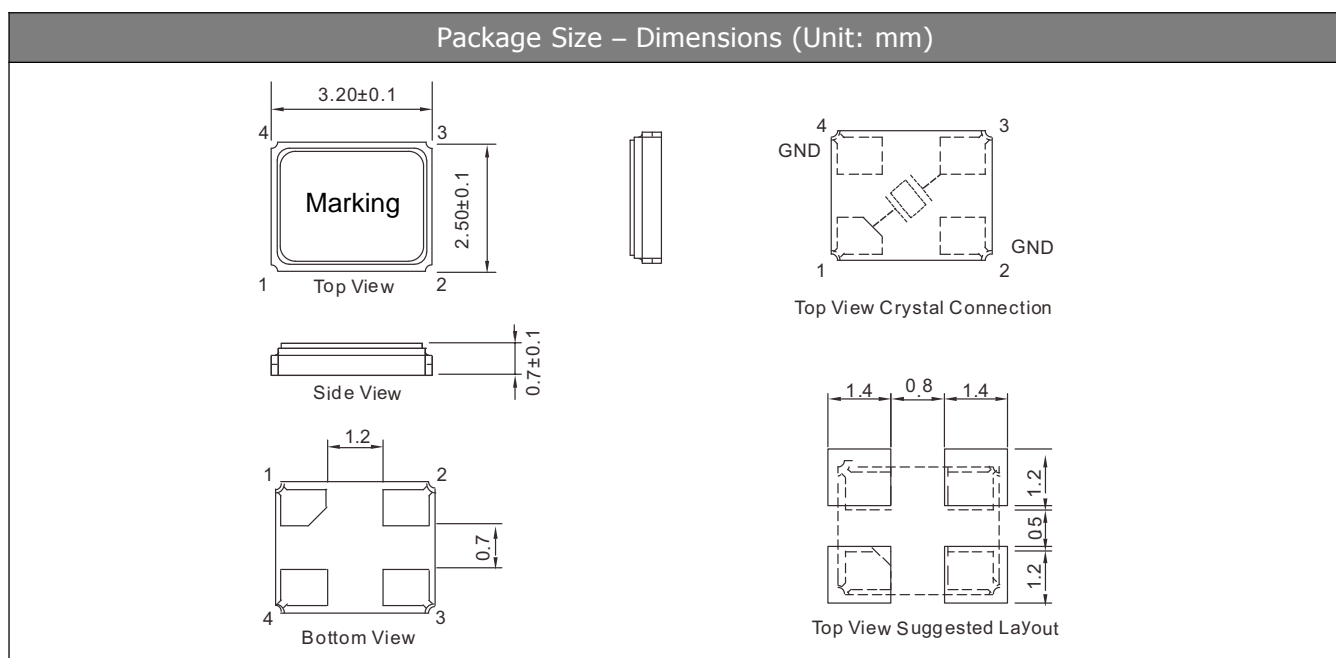

CRYSTAL UNIT

AEC-Q200

YSX321SC

Reflow Soldering Profile



Pre Heating Temperature

Tp1 ~ Tp2 = + 170 °C

Heating Temperature

TMLt = + 220 °C

Peek Temperature

TMax. = + 260 °C

Point of measuring

In case of Solder ability

Terminal.

In case of Resistance to soldering heat Surface.

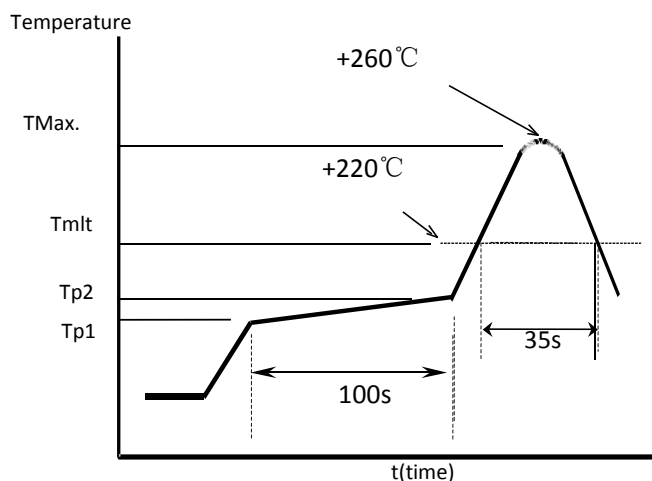

Taping Specification(Unit: mm)

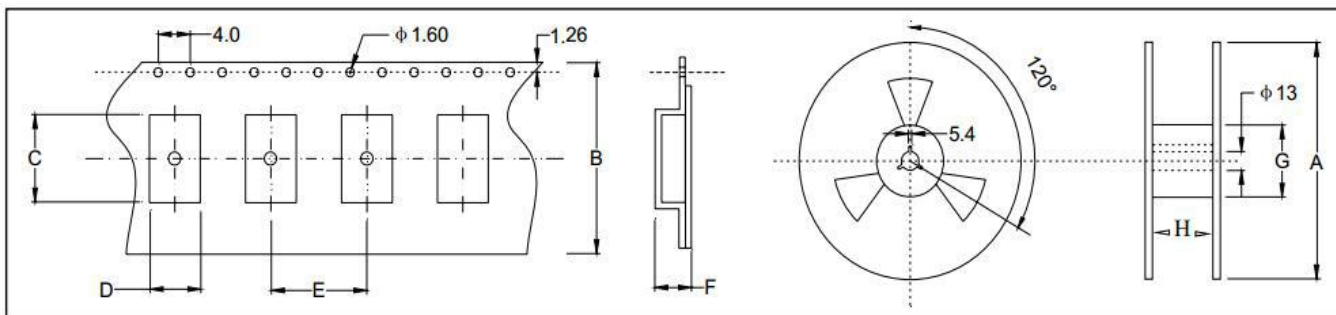

Size	A	B	C	D	E	F	G	H
SMD-3225	180±2.0	8.0±0.3	3.80±0.1	3.04±0.1	4.0±0.1	1.54±0.1	61.0±1.0	8.0±1.0

3000 pcs per reel