

CRYSTAL UNIT

YSX221SL Small Size



Applications

- SmartWearable IOT Communication.

Features

- Dimensions: 2.55 x 2.05 x 0.55 mm.
- Standard Frequency: 12 to 54MHz
- High precision and high frequency stability.
- Excellent heat resistance and environmental characteristics.

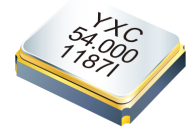

Specifications

Standard Frequency	12 to 54 MHz
Vibration Mode	AT Fundamental
Load Capacitance	8pF, 10pF, 20pF, or specify
Frequency Tolerance (at 25 °C)	±10ppm, ±20ppm, or specify
Frequency Versus Temperature Characteristics	±20ppm, or specify
Operating Temperature	-20~+70 °C, -40~+85 °C, or specify
Storage Temperature	-40~+85 °C or specify
Shunt Capacitance	3 pF Max.
Level of Drive	1~200µW Max. (100uW typical)
Aging (at 25 °C)	±3ppm/year Max.

Equivalent Series Resistance(ESR)

Fundamental	
12 ~ 14 MHz	150 Ω Max.
14 ~ 30 MHz	100 Ω Max.
30 ~ 48 MHz	60 Ω Max.
48 ~ 54 MHz	50 Ω Max.

Dimensions and Patterns [unit:mm]

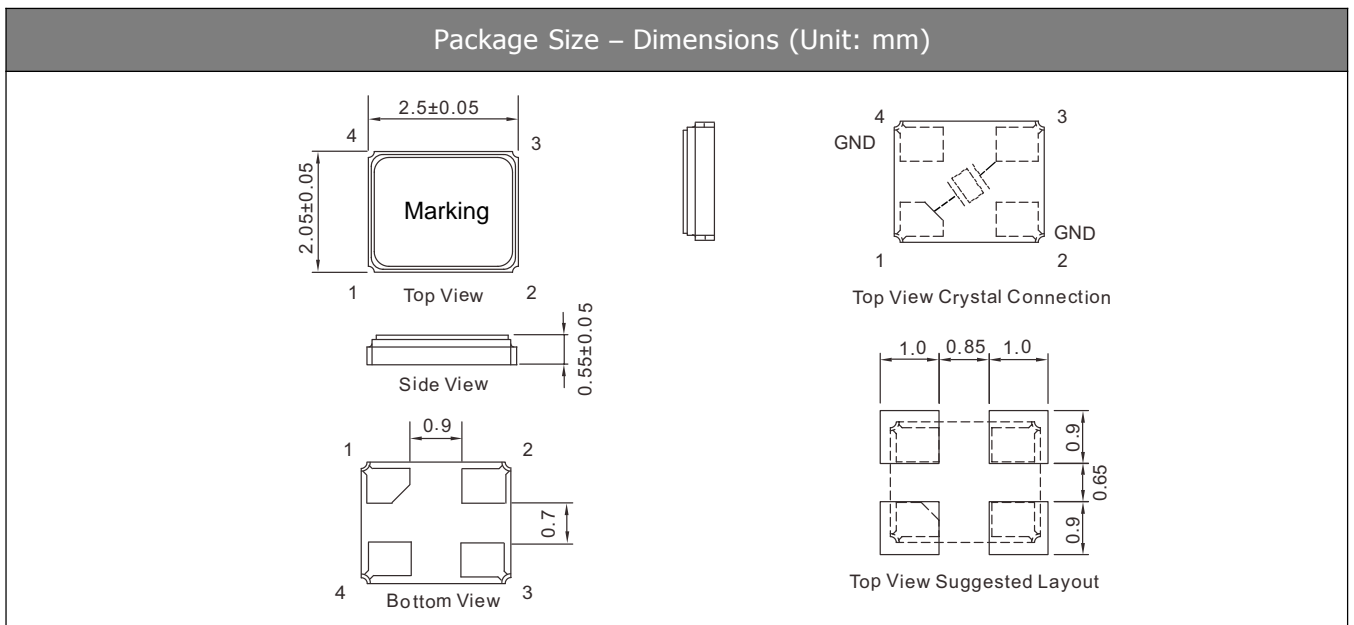

CRYSTAL UNIT

YSX221SL Small Size



Reflow Soldering Profile

Pre Heating Temperature

 Tp1 ~ Tp2 = + 170 °C

Heating Temperature

 TMI = + 220 °C

Peak Temperature

 TMax. = + 260 °C

Point of measuring

 In case of Solder ability

Terminal.

 In case of Resistance to soldering heat
 Surface.

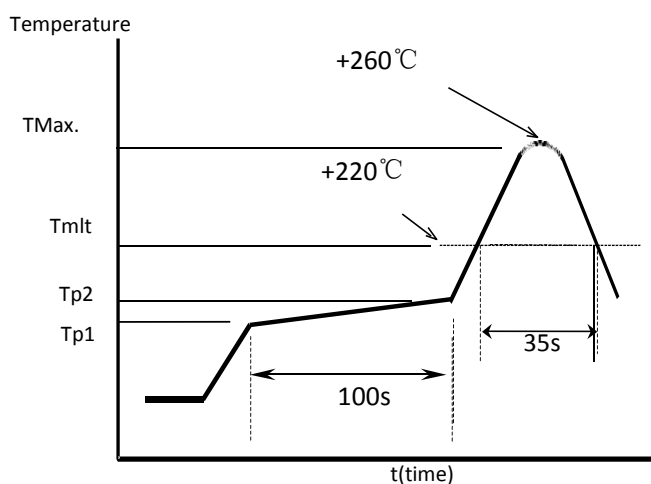

Taping Specification(Unit: mm)

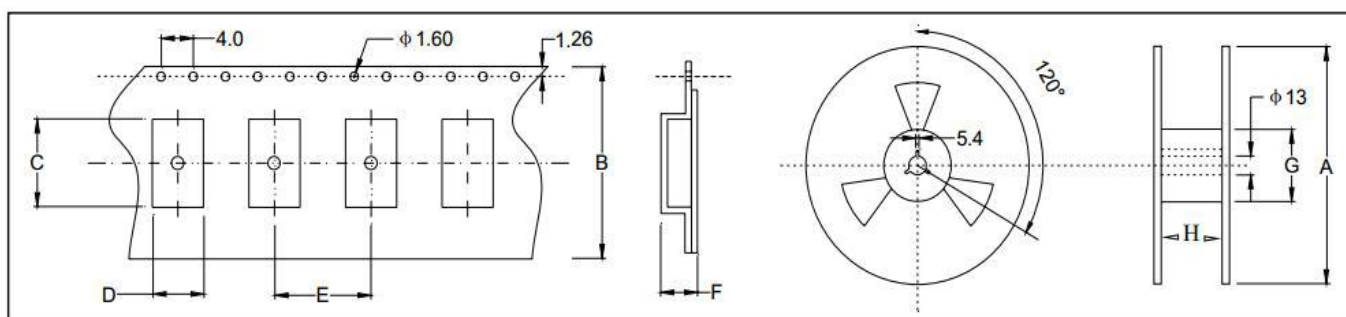

Size	A	B	C	D	E	F	G	H
SMD-2520	180±2.0	8.0±0.3	2.70±0.1	2.25±0.1	4.0±0.1	1.05±0.1	61.0±1.0	8.0±1.0

3000 pcs per reel