

# CRYSTAL UNIT

## YSX1612SL Small Size



### Applications

- SmartWearable TWS IOT Communication.

### Features

- Dimensions:1.60 x 1.20 x 0.35 mm.
- Standard Frequency:24~60MHz
- High precision and high frequency stability.
- Excellent heat resistance and environmental characteristics.

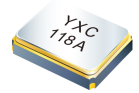

## Specifications

Standard Frequency	24~60 MHz
Vibration Mode	AT Fundamental
Load Capacitance	8pF,9pF,12pF,or specify
Frequency Tolerance (at 25 )	±10ppm,±20ppm,or specify
Frequency Versus Temperature Characteristics	±20ppm,or specify
Operating Temperature	-20~+70℃, -40~+85℃, or specify
Storage Temperature	-40~+85℃, or specify
Shunt Capacitance	3 pF Max.
Level of Drive	100 μWMax.
Aging (at 25 ℃ )	±2ppm/year Max.

## Equivalent Series Resistance(ESR)

Fundamental	
32 ~ 40 MHz	150 Ω Max.
41 ~ 60 MHz	100 Ω Max.

## Dimensions and Patterns [unit:mm]

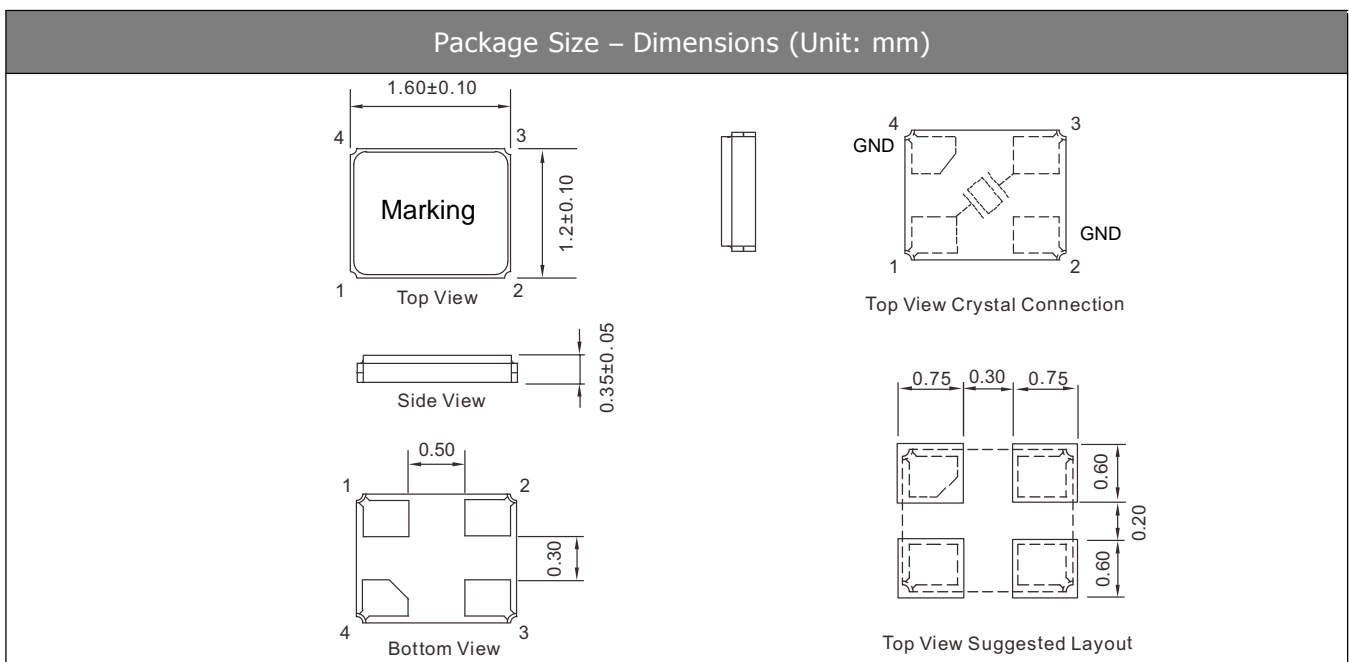

# CRYSTAL UNIT

## YSX1612SL *Small Size*



### Reflow Soldering Profile

Pre Heating Temperature  
 Tp1 ~ Tp2 = + 170 °C  
 Heating Temperature  
 TMLt = + 220 °C  
 Peak Temperature  
 TMax. = + 260 °C  
 Point of measuring  
 In case of Solder ability  
 Terminal.  
 In case of Resistance to soldering heat  
 Surface.

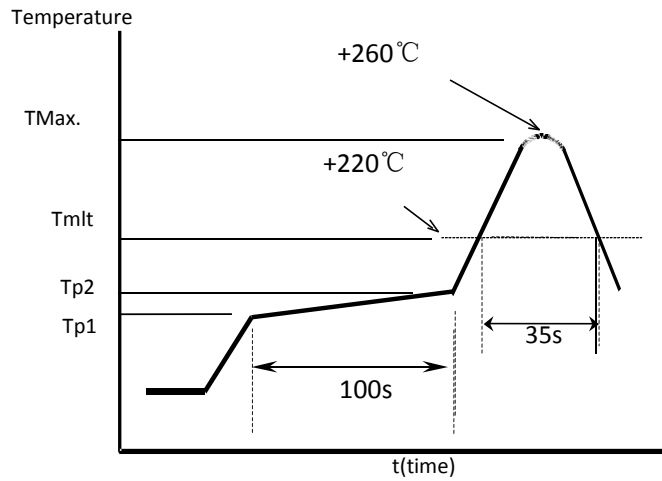

### Taping Specification(Unit: mm)

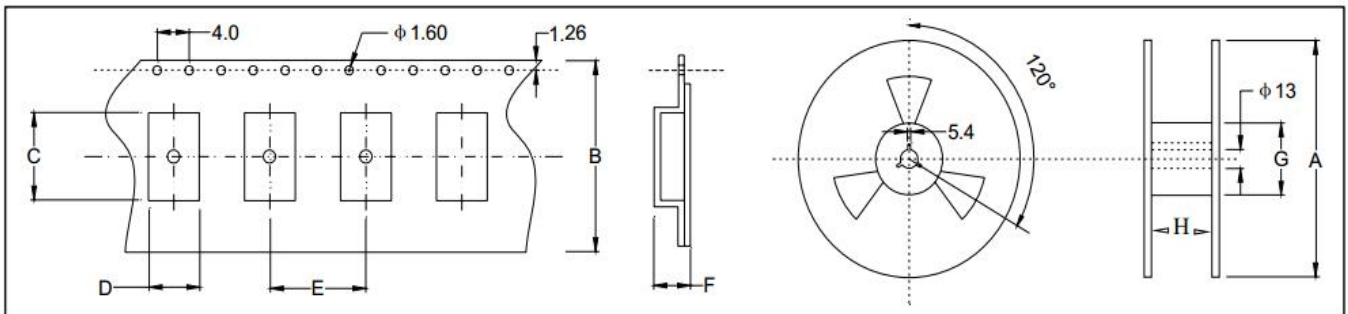

Size	A	B	C	D	E	F	G	H
SMD-1612	180±2.0	8.0±0.3	1.85±0.1	1.45±0.1	4.0±0.1	0.45±0.1	61.0±1.0	8.0±1.0

3000 pcs per reel