

CRYSTAL UNIT

YSX530GA

Glass Sealed



Applications

- Industrial Control Consumers.

Features

- Dimensions: 5.00 x 3.20 x 1.20 mm.
- Standard Frequency: 8~54MHz
- 2 pads SMD glass sealed crystal units.
- Contains Pb in sealing glass exempted by RoHS directive.

Specifications

Standard Frequency	8~54 MHz
Vibration Mode	AT Fundamental
Load Capacitance	10pF, 20pF, or specify
Frequency Tolerance (at 25 °C)	±10ppm, ±20ppm, or specify
Frequency Versus Temperature Characteristics	±20ppm, or specify
Operating Temperature	-20~+70°C, -40~+85°C, or specify
Storage Temperature	-55~+125°C or specify
Shunt Capacitance	5 pF Max.
Level of Drive	1~300µW Max. (100uW typical)
Aging (at 25 °C)	±3ppm/year Max.

Equivalent Series Resistance(ESR)

Fundamental	
8 ~ 16MHz	80 Ω Max.
16 ~ 25 MHz	40~60 Ω Max.
25 ~ 54 MHz	30~40 Ω Max.

Dimensions and Patterns [unit:mm]

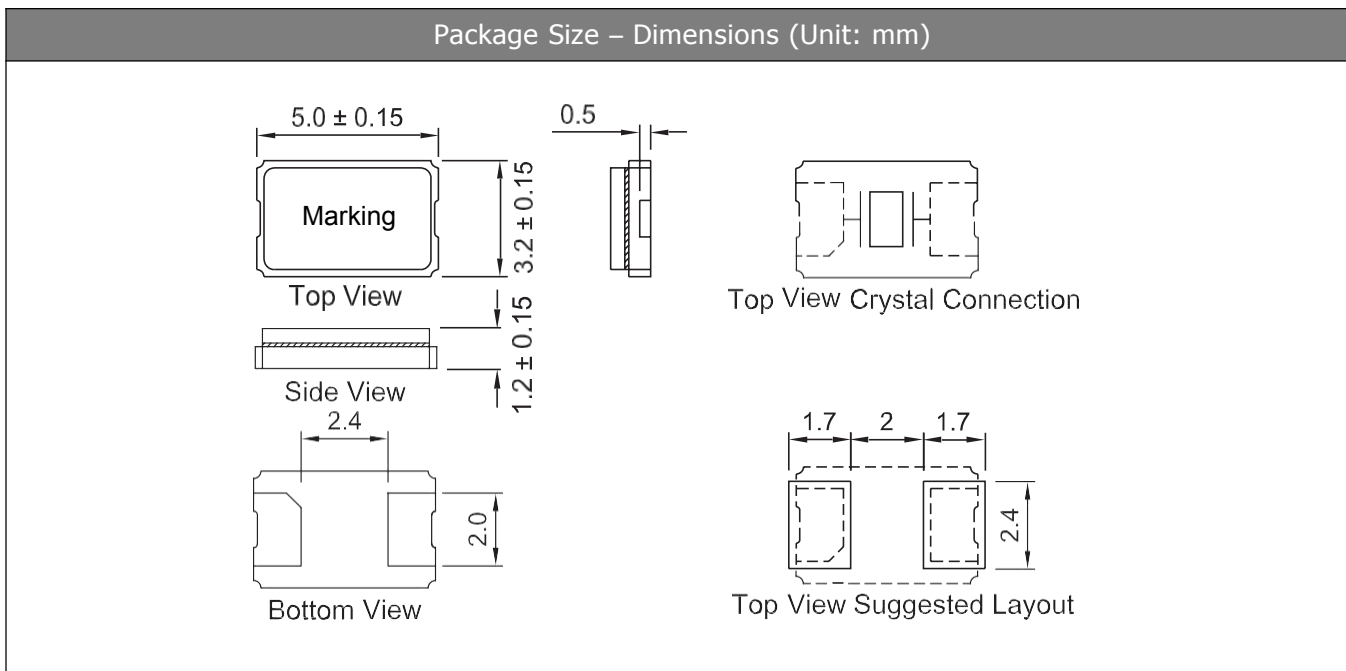

CRYSTAL UNIT

YSX530GA

Glass Sealed



Reflow Soldering Profile

Pre Heating Temperature
 Tp1 ~ Tp2 = + 170 °C
 Heating Temperature
 TMI = + 220 °C
 Peak Temperature
 TMax. = + 260 °C
 Point of measuring
 In case of Solder ability
 Terminal.
 In case of Resistance to soldering heat
 Surface.

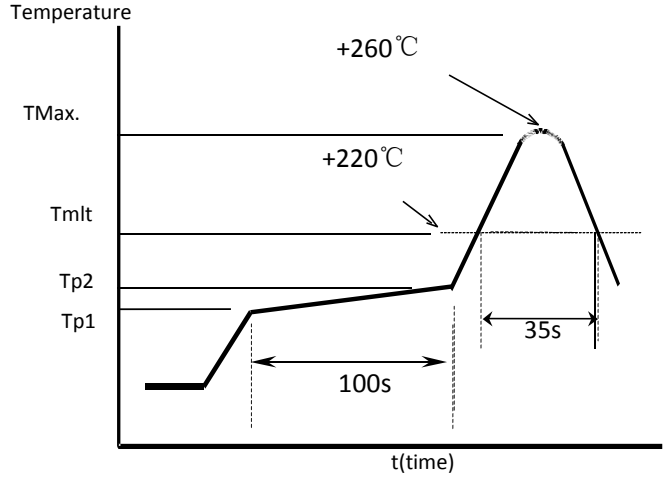

Taping Specification(Unit: mm)

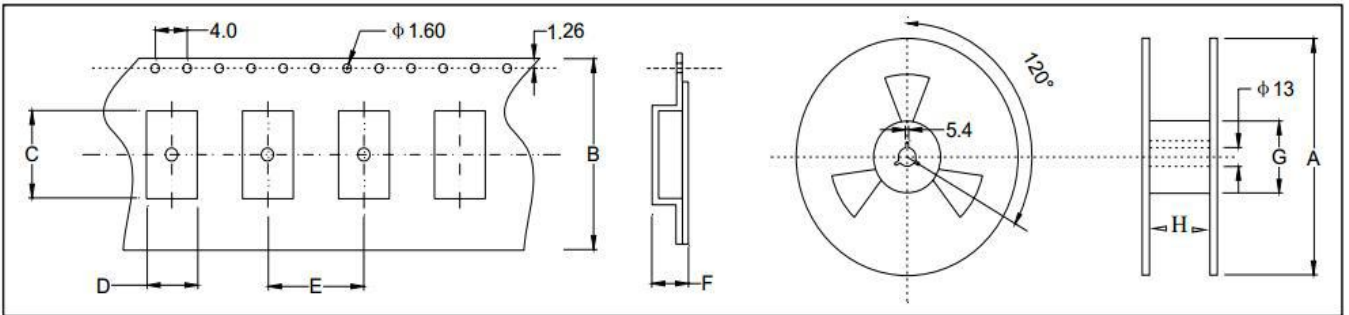

Size	A	B	C	D	E	F	G	H
SMD-5032	180±2.0	12.0±0.3	6.35±0.1	3.85±0.1	8.00±0.3	1.80±0.1	61.0±1.0	12.0±1.0

1000 pcs per reel